

PROGRAMIRANJE ROBOTOV S POMOČJO NAPREDNIH PROGRAMSKIH ORODIJ IN UI

Tomaž Lasič, ABB Robotics d.o.o.

Vsebina

- 01 **ABB Robotics bo prevzela skupina SoftBank**
- 02 **Vizija - AVP™ Autonomous Versatile Robotics**
- 03 **RobotStudio – temeljno orodje**
- 04 **EyeMotion z UI in Avtomatsko generiranje trajektorij brez kolizij**
- 05 **Visual SLAM navigacija s pomočjo UI**
- 06 **RobotStudio HyperReality**

ABB Robotics to be acquired by SoftBank Group

Strong customer value proposition by combining ABB Robotics' leading technology and industry expertise with SoftBank's state-of-the-art capabilities in AI, robotics and next-generation computing



No change in working relationship with our customers and partners



SoftBank is a globally recognized technology group and investor/operator focused on AI, robotics, and next-generation computing.



Transaction value: USD 5.375 billion



The deal is anticipated to close in the second half of 2026, subject to regulatory approvals.

ABB Robotics and SoftBank Group share the same vision that the world is entering a new era of AI-based robotics and believe that we can best shape this era together.



AI Chip

**AI
Data Center**

AI Robot

ASI
Artificial Super
Intelligence

Energy

Mobilizing the full strength of the Group to realize ASI

Chip

arm

AMPERE. GRAPHCORE

Data Center

Stargate

AI Model

Robot

ABB Robotics

Robo HD

AGILE ROBOTS SoftBank Robotics
BERKSHIRE GREY BALYO AutoStore

OpenAI

Power

SB Energy

A Key Piece Added toward
Realizing ASI

AVR™ Autonomous Versatile Robotics

Nova generacija ABB ROBOTOV

Versatility

Autonomy

Generative
AI

ABB Roboti bodo razumeli okolje in načrtovali samostojno.

Opravljali bodo več nalog, na več mestih, hitreje, varneje in pametneje.

Z njimi bomo sodelovali naravno – tako, kot sodelujemo drug z drugim.

Šest osnovnih
blokov v smeri
AVR™
Autonomous
Versatile Robots





ABB Robotics

**AUTONOMOUS VERSATILE
ROBOTS**

Osnovno orodje - RobotStudio®

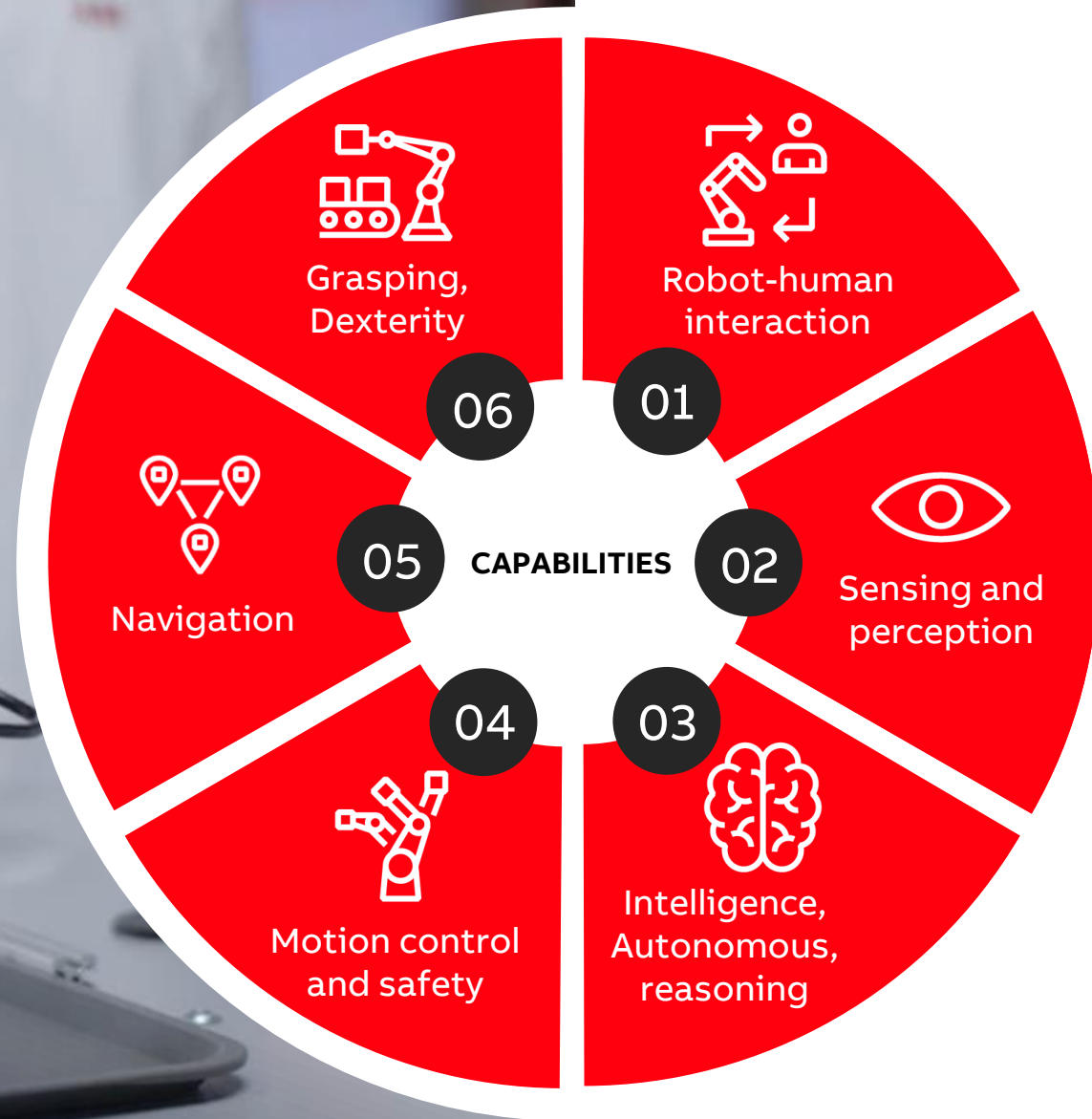
Virtual Robot Controller

Popolna kopija robotske celice z istim programom kot ga ima realni robot.

- Kar vidite, to dobite.
- Ustvarite svojo robotsko celico virtualno in pospešite proizvodnjo.



ABB ima popolno rešitev

TrueMove

Visoka natančnost trajektorij neodvisna od hitrosti robota

Kalibracija

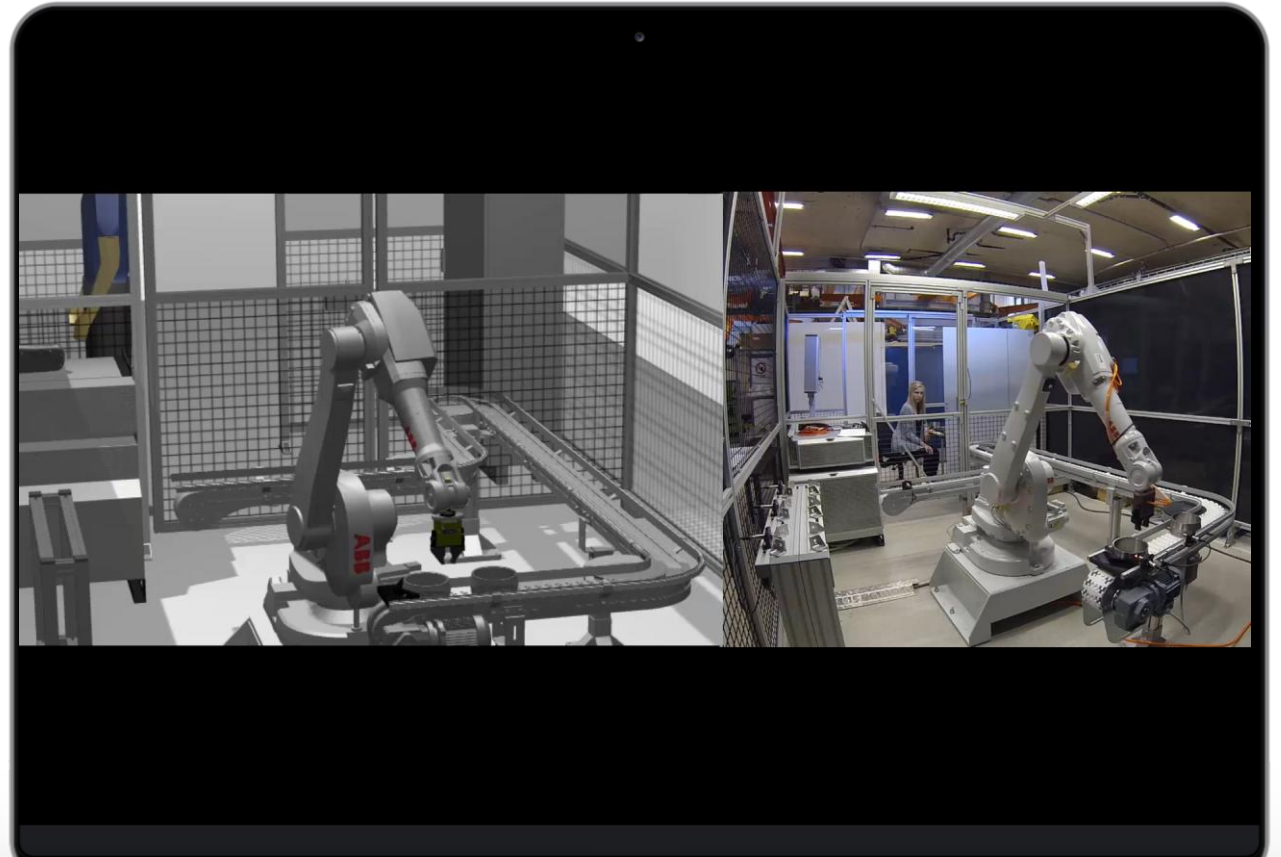
Povezava koordinatnih sistemov in RAPID programski jezik

Virtualni robotski krmilnik

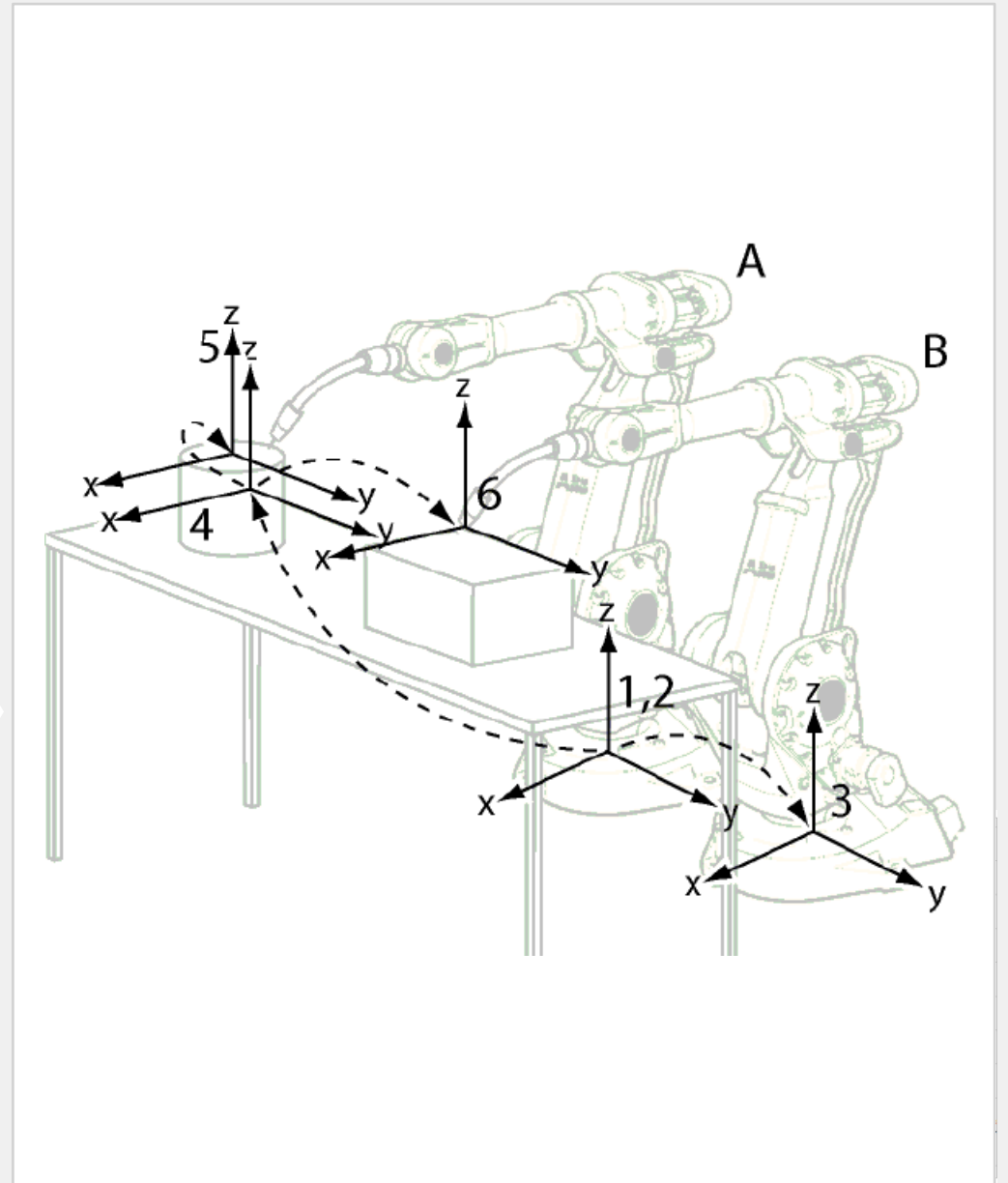

RobotStudio®

Collision Avoidance

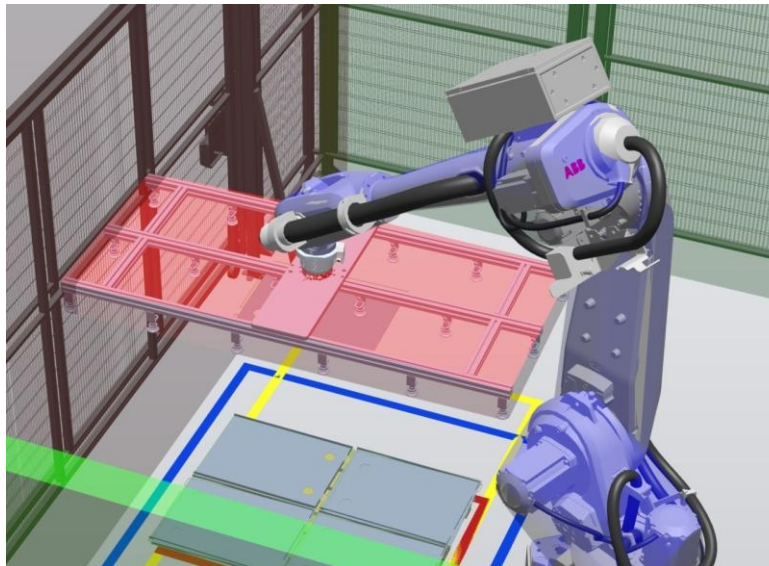
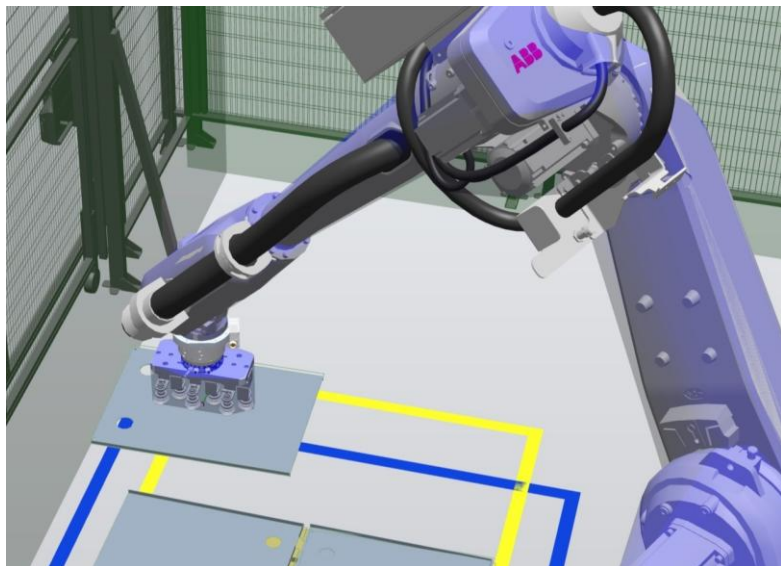

Izvajanje v realnem času

Poleg robota so vključeni vsi objekti na robotu in okolica.

Ob menjavi prijemala se spremeni tudi geometrija virtualne kapsule prijemala.

Omogoča preverjanje morebitnih kolizij že v fazi programiranja v virtualnem okolju.

Med izvajanje programa prepreči poškodbe ob programskih napakah.

Prepreči kolizijo v fazi simulacije in tudi med realnim izvajanjem programa

RobotStudio®

Automatic Collision Free Path Planning

Avtomatsko generiranje trajektorij brez kolizij

- Optimalna pot
- Krajši čas programiranja
- Manjša obraba

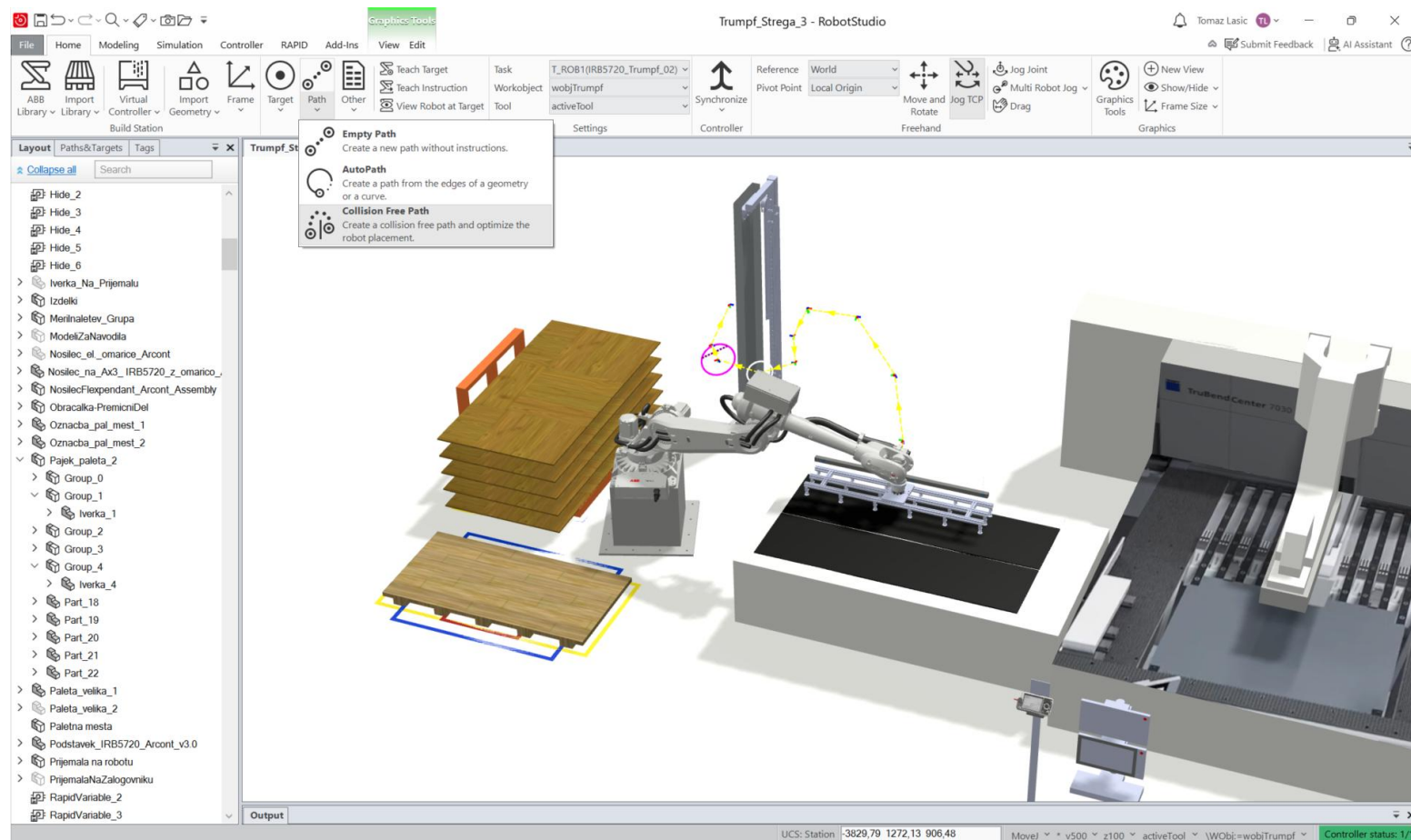

Programska podpora za zmanjšanje porabe energije

Automatic path planning – Avtomatsko generiranje trajektorije

Ročno programiranje

Avtomatsko generiranje trajektorij



Poraba energije
➤ **-36%**

Zmanjšanje
sunkovitih gibov
podaljša življenjsko
dobo.



3.24 s



Proizvodni cikel



1.2 s

3.6 kJ



Poraba energije



2.3 kJ

Automatic, collision-free path planning online

Neposredno v realnem času



Samostojno: Upravlja variante in optimizira trajektorije v dinamičnih in spreminjajočih se okoljih.



Vsestransko: vsestranski robot se prilagodi in preklopi med različnimi aplikacijami, od pobiranja kartonov do paketov različnih velikosti in mase...



Do 50% krajši proizvodnji cikel*

*compared to manual programming

© 2026 ABB. All rights reserved.

Stran 14

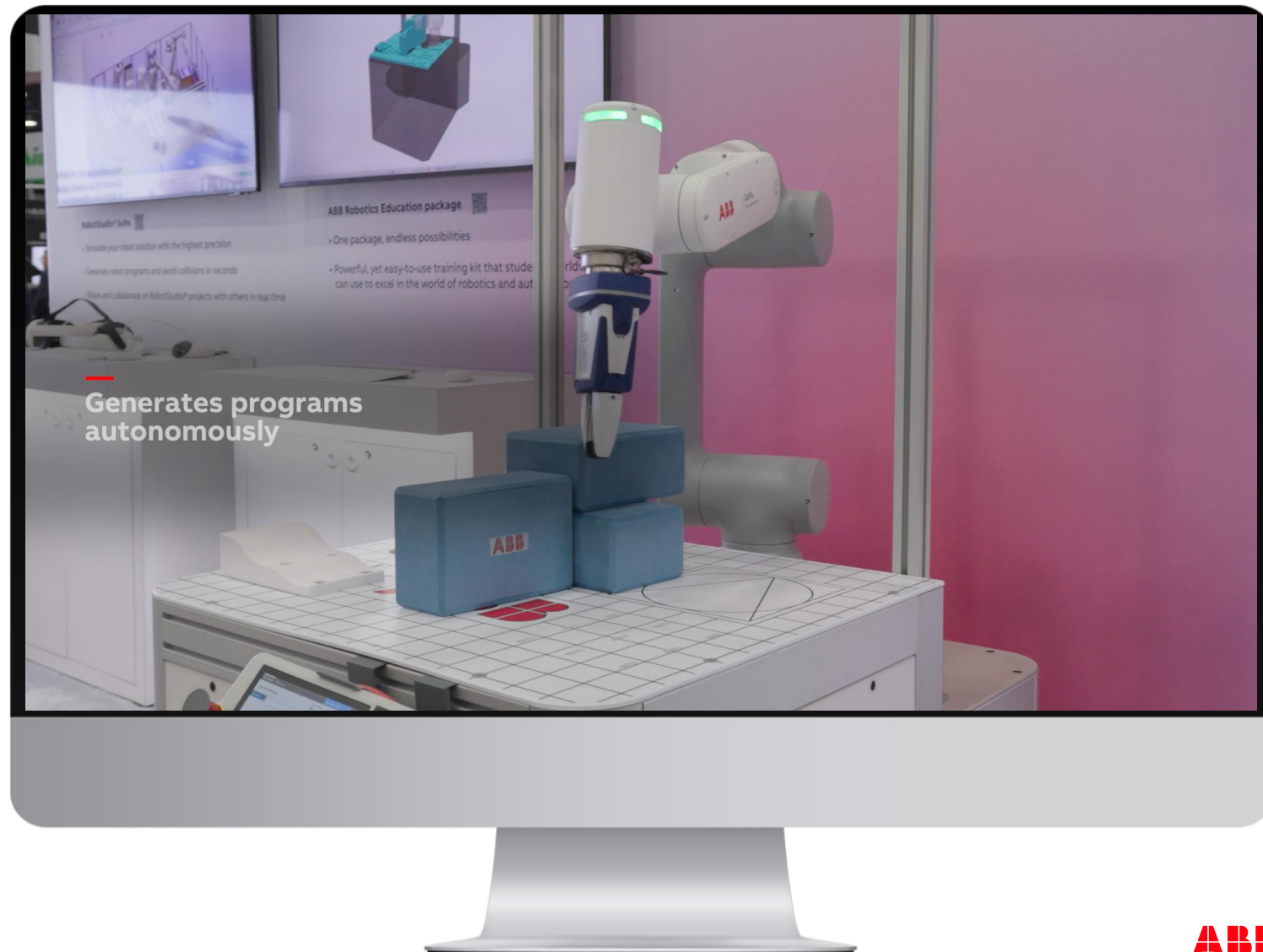

ABB

ABB Robotic Parcel Inductor

Kjer vsak paket najde svoje mesto



- Vnaprej naučen AI vision
(Na tisoče paketov)
- Upravljanje z
singularnostjo,
trajektorijami brez kolizij
in optimalno hitrostjo
- Različne konfiguracije
(2 robota: IRB 1300, IRB
2600)
- Prijemalo z 9 sesalkami



1,500 pak/h
produktivnost



10 kg
nosilnost



99.5%
natančnost

Tipi paketov:

- Vrečke
- Polivinil vrečke
- Kvadratne oblike

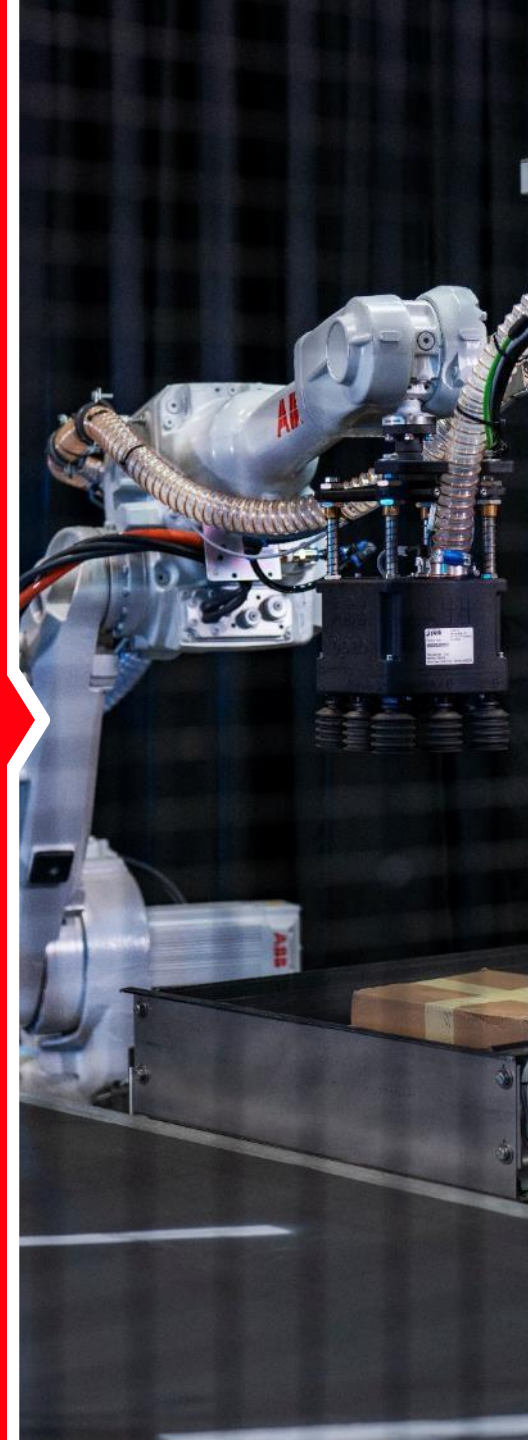

Online Automatic path planning

Offline to online

Trajektorije brez kolizij v realnem času

- Optimalna trajektorija in cikel v dinamično spreminjajočem okolju.
- Zaznavanje podatkov okolja v realnem času.
- Poveča zmogljivost mehanskega sistema ob ohranitvi zanesljivosti in vzdržljivosti.



ABB Item Picking Family

ABB strojni vid na osnovi umetne inteligence

ABB AI vision

- Napreden **vnaprej naučen** strojni vid na osnovi **umetne inteligence** za razpoznavanje, ravnanje in razvrščanje, ki omogoča hitro naročanje.
- Sposoben je razpoznati različne vrste predmetov v zahtevnih pogojih (npr. oblačila v vrečkah) z **99,5% natančnostjo razpoznavanja**.

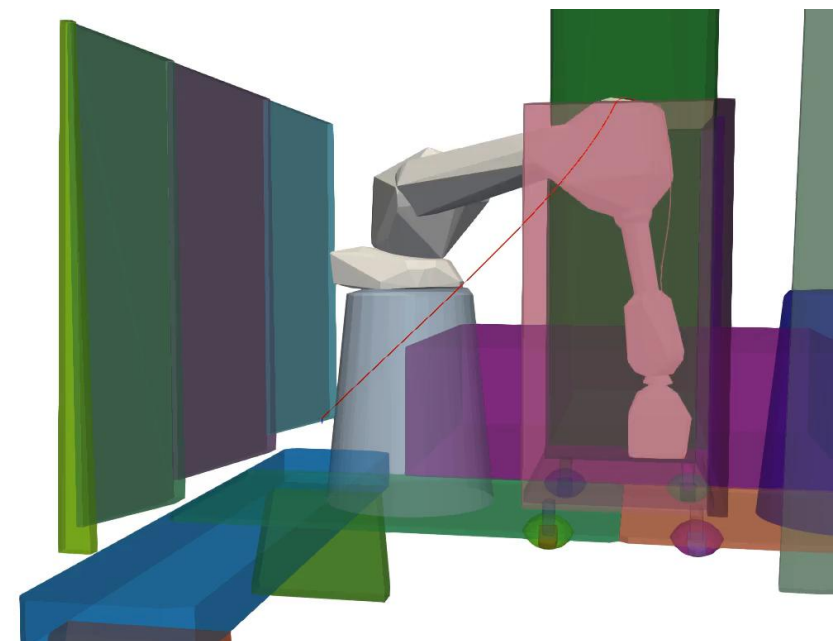
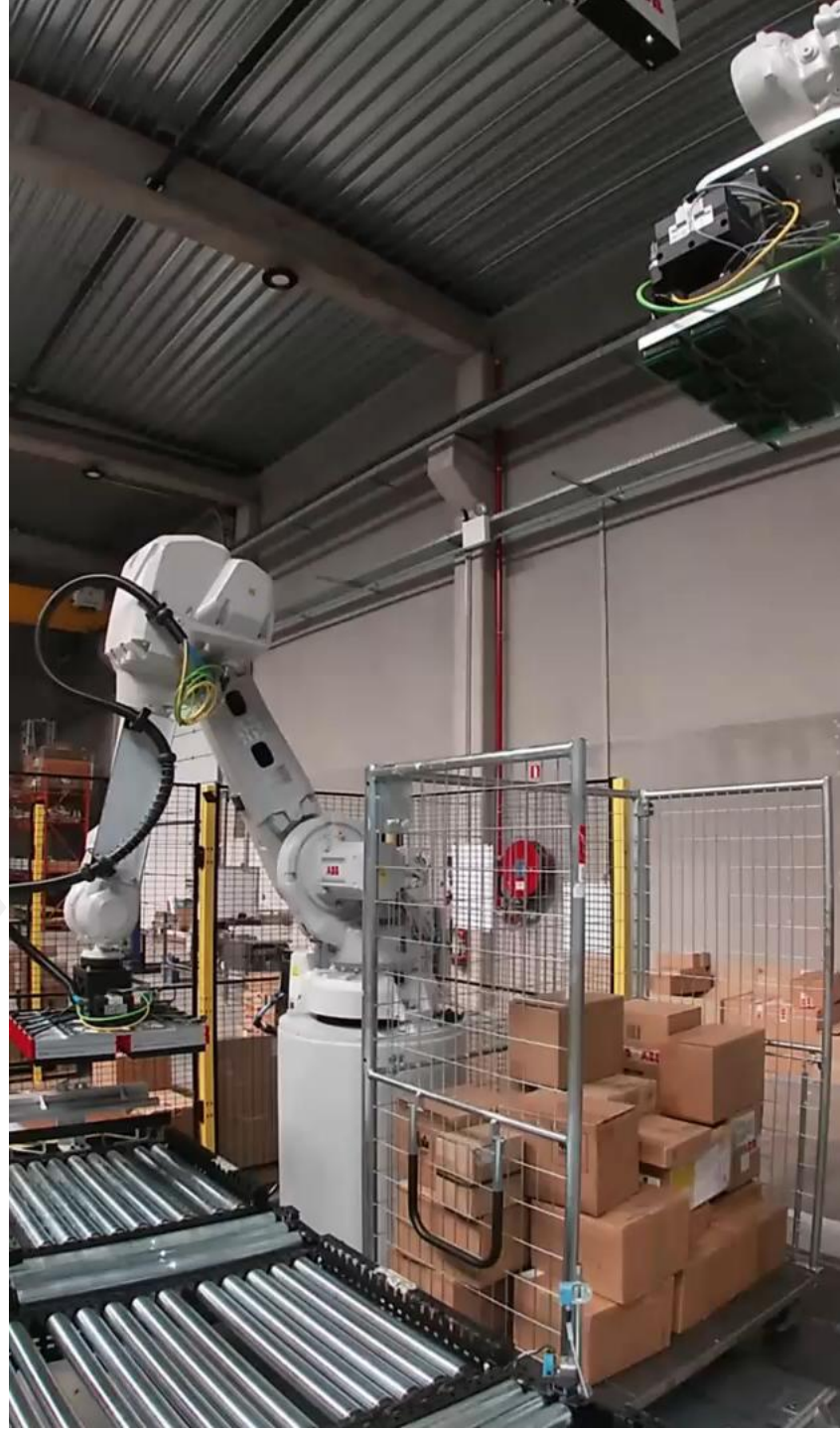
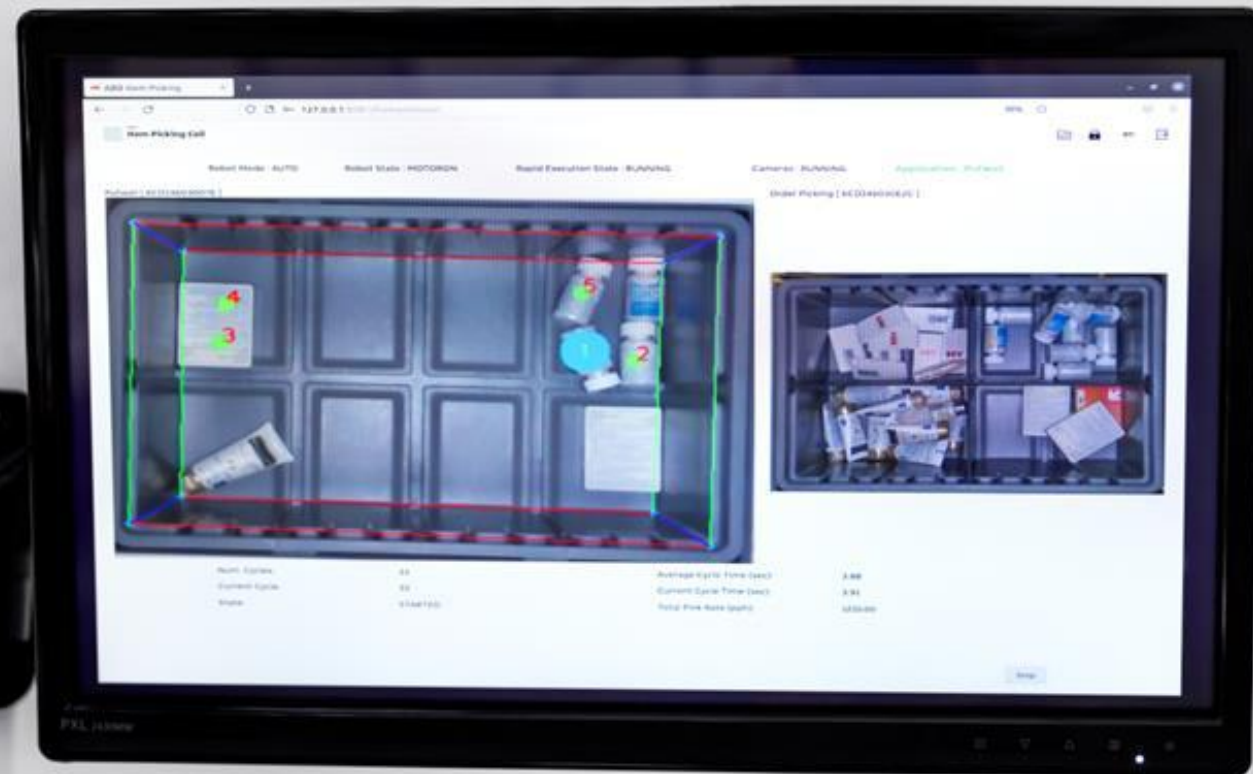

OmniCore - EyeMotion

Programsko orodje za sestavo sistema s strojnimi vidom in inteligentnim vodenjem

**HOW CAN
A ROBOT GET EYES**
and the intelligence
to use them?



OMNICORE™ EYEMOTION
Advanced Eyes
and Intelligent Motion



FLEXIBILITY
Unique, hardware-agnostic
vision software through any
camera or sensor



OmniCore - EyeMotion

Enostavno zlaganje funkcionalnih blokov od vida do vodenja brez kolizij

SIMPLICITY

Simple web interface through drag and drop functional blocks

Up to **90%** reduction in commission time



*versus comparable solutions on the market

INTELLIGENCE

Combined with unique automatic, collision-free path planning online

Up to **50%** reduction in cycle time



*compared to manual programming

Supports **ALL** OmniCore-powered **ROBOTS**



AppStudio

Grafični vmesnik

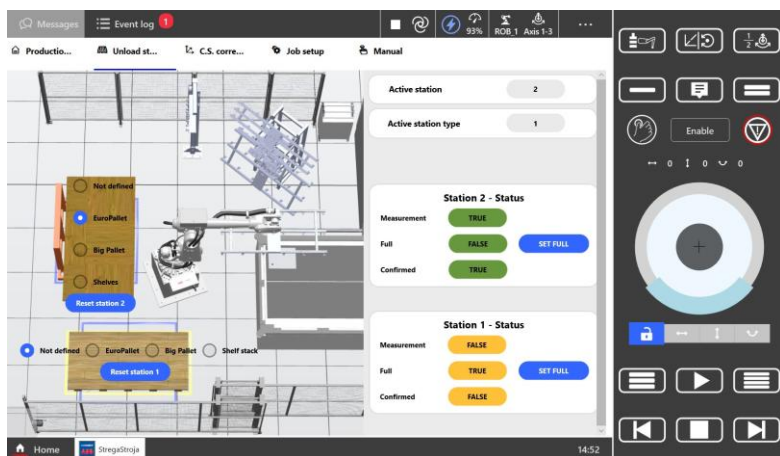

Aplikacija:

- Podpora proizvodnji
- Kreiranje novih receptur
- Servisna okna

AppStudio značilnosti

- Web aplikacija
- Program deluje brez RobotStudia
- Brezplačen
- Od enostavnih do kompleksnih aplikacij
- Možnost uporabe različnih platform (FlexPendant, PC, Tablice, SmartPhone)

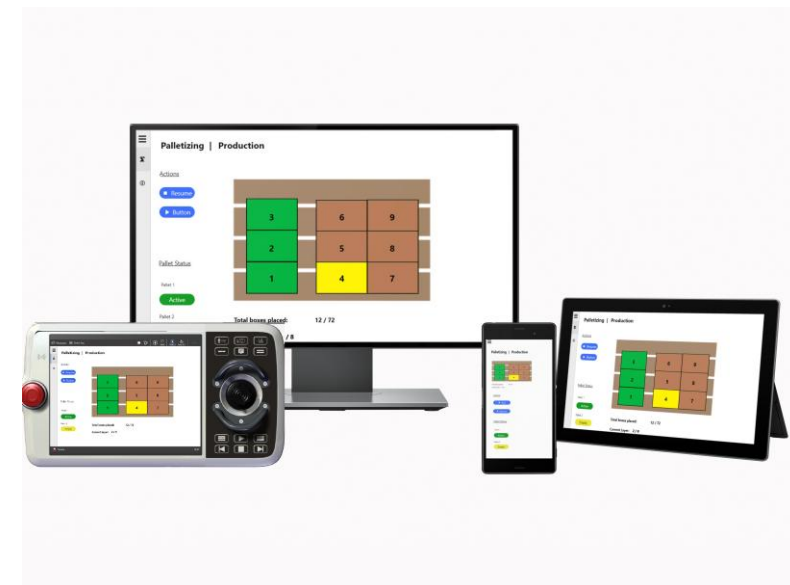

RobotStudio® AI Assistant

Primer: User guidance

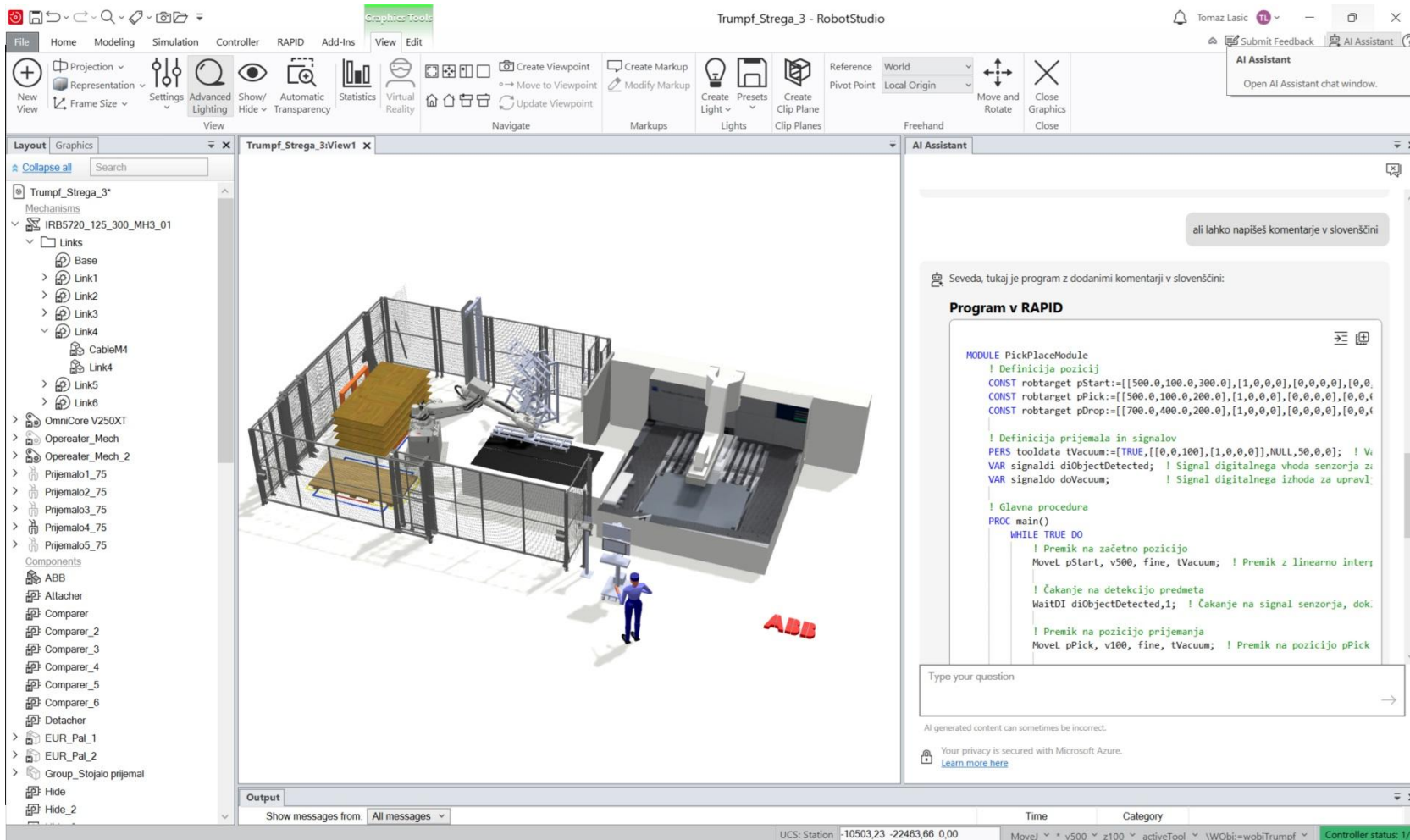

Navodila korak-za korakom

Podpora v realnem času

Odpravljanje napak

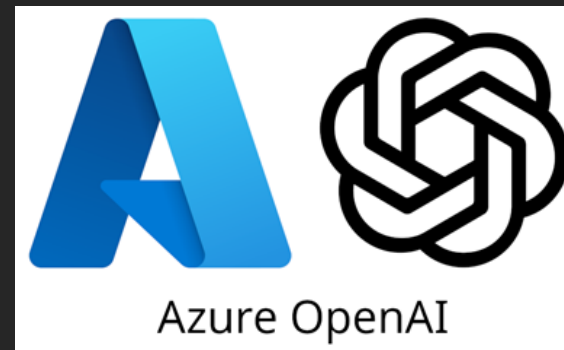

RobotStudio® AI Assistant

Primer: podpora RAPID

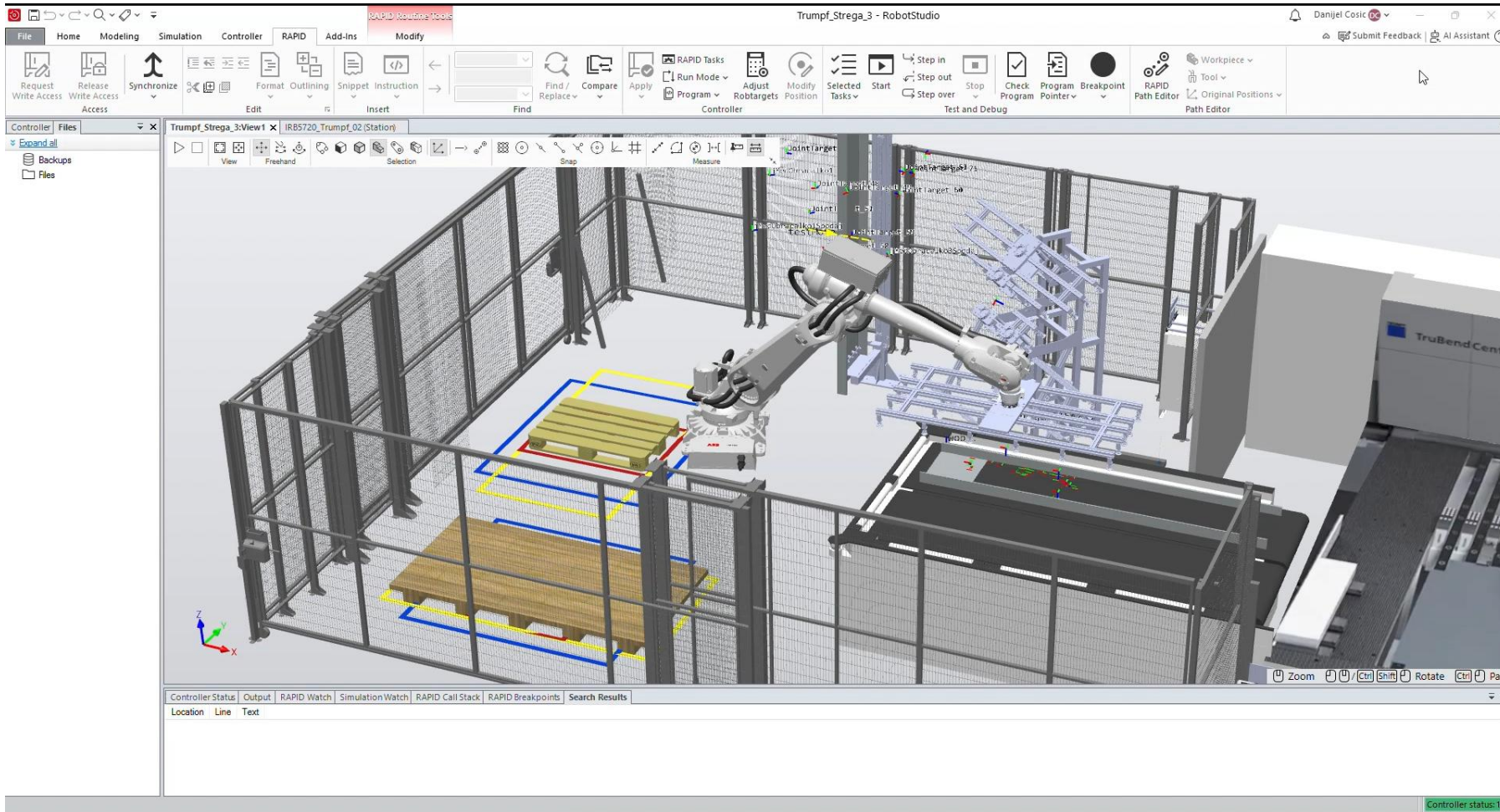

Azure OpenAI

Visual SLAM - za AMR

Zaznavanje okolice in navigacija na osnovi uporabe umetne inteligence

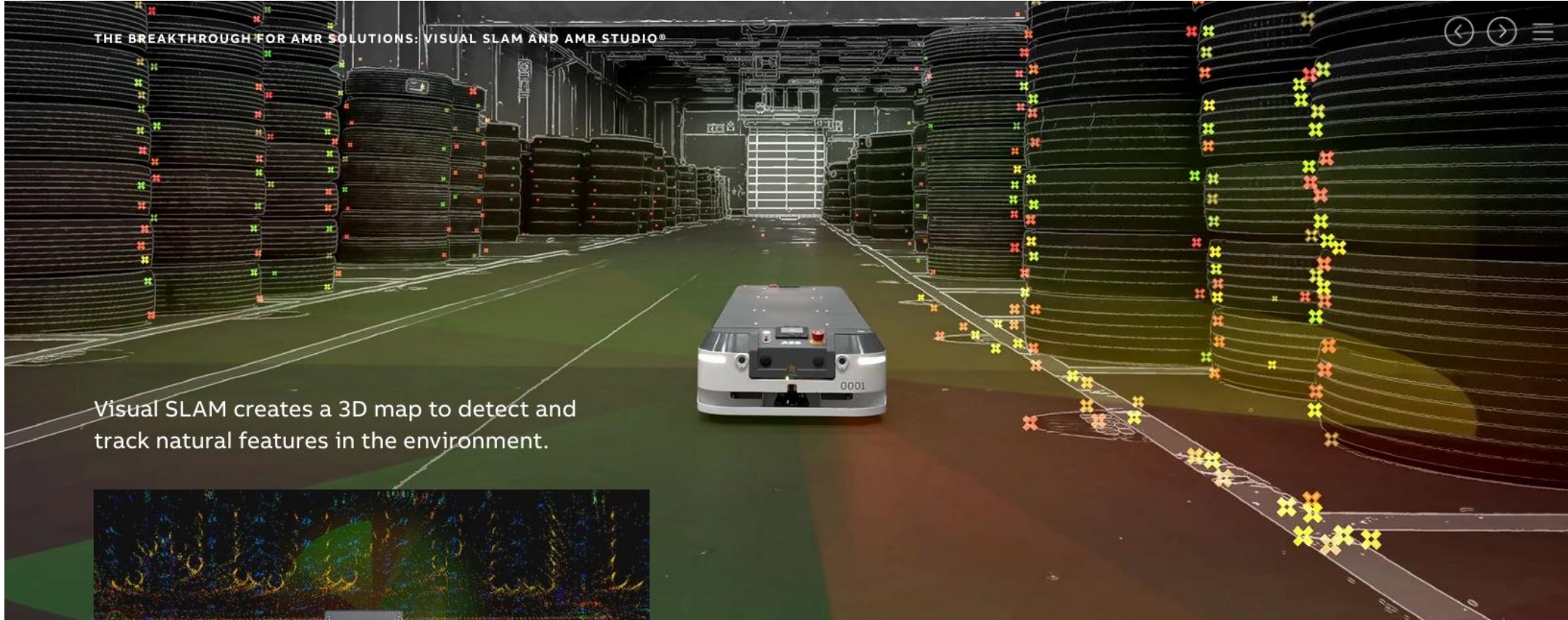

Visual SLAM creates a 3D map to detect and track natural features in the environment.

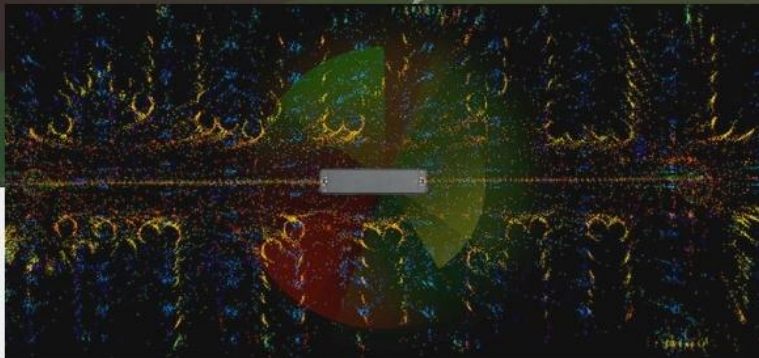

Visual SLAM creates a **3D map** by using **off-the-shelf cameras to detect and track natural features in the environment**, enabling AMRs to locate their position and navigate without requiring additional infrastructure. Additionally, the map updates itself automatically whenever changes in the environment are detected, ensuring that the AMR remains accurate and efficient.

Key differentiators: Alphasense Autonomy - powered mobile robots

ABB's Alphasense Autonomy delivers **four key benefits** to mobile robots.



Adaptive:

Working out-of-the-box in any environment.



Robust to change:

Working reliably in complex, dynamic spaces.



Flexible:

Ready for heterogeneous fleets of robots.



Smart:

Understanding the environment to achieve human-like smartness and effectiveness.

Alphasense Autonomy leverages technological capabilities to deliver value in practically any environment.

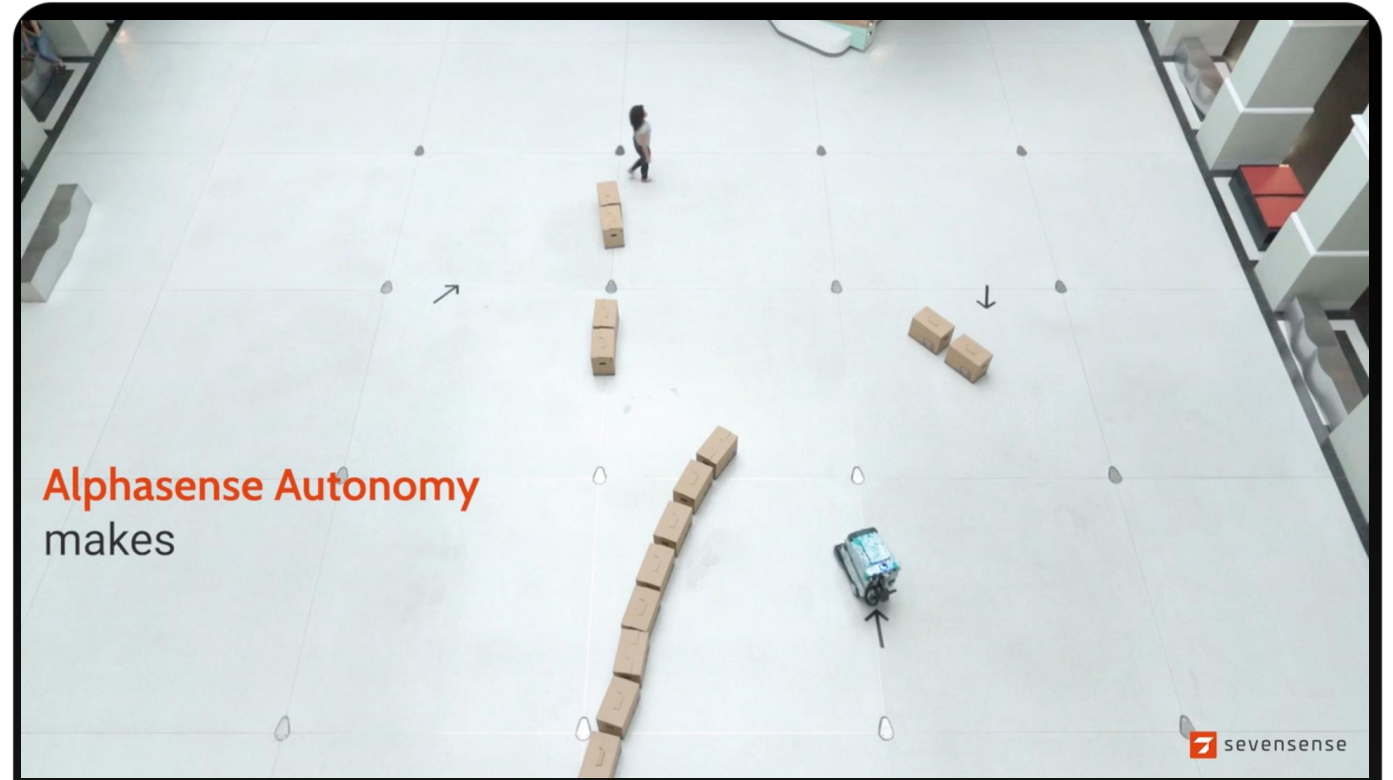



RobotStudio® HyperReality

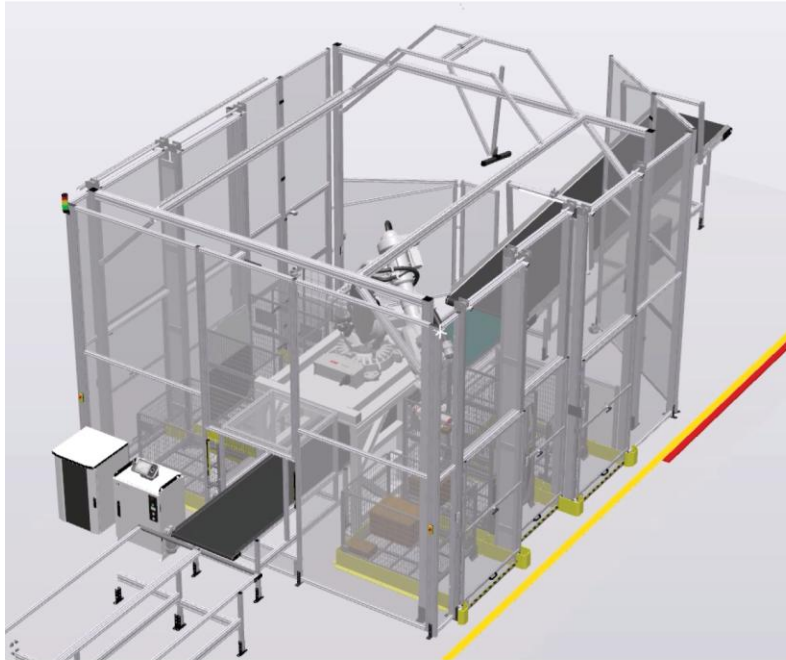

ABB